



NOVA line

NOVA Italia S.p.A.

Via Vecchia Scorciosa 33-35 - 66022 Fossacesia (Ch)

Tel. 0872 578934 (15 linee r.a.) - Fax 0872 57670

www.novaline.it - info@novaline.it

P.I.: 01956430696 - C.C.I.A.A. CH140833 - Capitale Sociale: € 1.100.000,00 i.v.



RAEE: IT08020000003247



Azienda con sistema

di gestione certificato

ISO 9001: 2015

Certificato N. IT 15/0141



NovaLine.it



novaline.it



novaline.it



2PTL60

PORTA TUBO T8 IP65 DOPPIO ATTACCO 60 CM,
ALIMENTAZIONE BIDIREZIONALE

INFORMAZIONI

Marca:NOVA LINE

Materiale:ABS+PC

Colore:Grigio

Dimensioni:684x101x56,8 mm

Uso:Interno

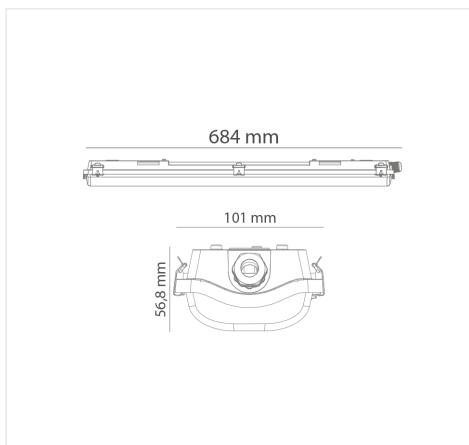

CARATTERISTICHE ELETTRICHE

Carico max Applicabile:2 x 9W

LOGISTICA

EAN Conf.:8028274113488

Pz per Conf.:1

ITF Inner:18028274113485

Pz Inner:10

