



novaline

NOVA Italia S.p.A.

Via Vecchia Scorciosa 33-35 - 66022 Fossacesia (Ch)

Tel. 0872 578934 (15 linee r.a.) - Fax 0872 57670

www.novaline.it - info@novaline.it

P.I.: 01956430696 - C.C.I.A.A. CH140833 - Capitale Sociale: € 1.100.000,00 i.v.



RAEE: IT0802000003247



Azienda con sistema

di gestione certificato

ISO 9001: 2015

Certificato N. IT 15/0141



NovaLine.it



novaline.it



novaline.it



2STL120

PORTA TUBO T8 DOPPIO ATTACCO 120 CM,
ALIMENTAZIONE BIDIREZIONALE

INFORMAZIONI

Marca:NOVA LINE

Materiale:Metallo

Colore:Bianco

Dimensioni:1200x80x30 mm

Uso:Interno

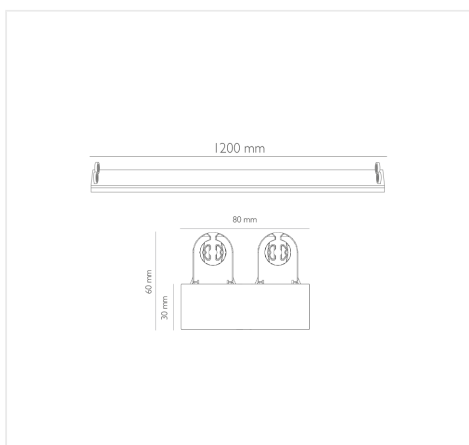

LOGISTICA

EAN Conf.:8028274103632

Pz per Conf.:1

ITF Inner:18028274103639

Pz Inner:18

Peso Lordo Kg:0.87222222222222

Altezza Inner cm:21.5

Profondità Inner cm:124.5

Peso Inner Kg:15.7

Altezza cm:123

Lunghezza cm:8.5

Profondità cm:3

