



NOVA line

NOVA Italia S.p.A.

Via Vecchia Scorciosa 33-35 - 66022 Fossacesia (Ch)

Tel. 0872 578934 (15 linee r.a.) - Fax 0872 57670

www.novaline.it - info@novaline.it

P.I.: 01956430696 - C.C.I.A.A. CH140833 - Capitale Sociale: € 1.100.000,00 i.v.



RAEE: IT0802000003247



Azienda con sistema

di gestione certificato

ISO 9001: 2015

Certificato N. IT 15/0141



NovaLine.it



novaline.it



novaline.it



GMR300L

STRUTTURA IN GESSO DA PARETE DA INCASSO,
100X100X49 MM

INFORMAZIONI

Marca:NOVA LINE

Materiale:Gesso + Metallo

Dimensioni:100x100x49 mm

Uso:Interno

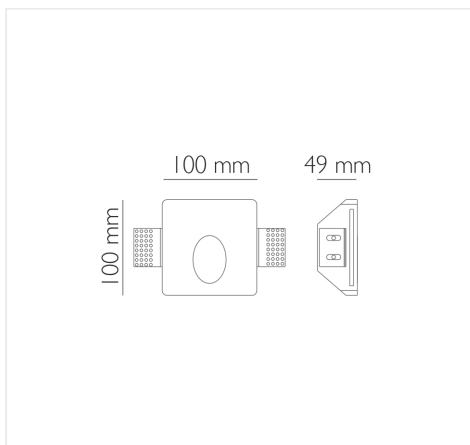

CARATTERISTICHE ELETTRICHE

Grado di Protezione:IP20

LOGISTICA

EAN Conf.:8028274105735

Pz per Conf.:1

ITF Inner:18028274105732

Pz Inner:24

Peso Lordo Kg:0.65616666666667

Tipo di Confezione:Box

Altezza Inner cm:47.5

Profondità Inner cm:53.5

Peso Inner Kg:15.748

Altezza cm:11

Lunghezza cm:17

Profondità cm:17.3

