



NOVA line

NOVA Italia S.p.A.

Via Vecchia Scorciosa 33-35 - 66022 Fossacesia (Ch)

Tel. 0872 578934 (15 linee r.a.) - Fax 0872 57670

www.novaline.it - info@novaline.it

P.I.: 01956430696 - C.C.I.A.A. CH140833 - Capitale Sociale: € 1.100.000,00 i.v.



RAEE: IT08020000003247



Azienda con sistema

di gestione certificato

ISO 9001: 2015

Certificato N. IT 15/0141



NovaLine.it



novaline.it



novaline.it



LK2003

KIT PLACCA 3 MODULI CON SUPPORTO COLORE ALLUMINIO

INFORMAZIONI

Marca:NOVA LINE

Colore:Alluminio

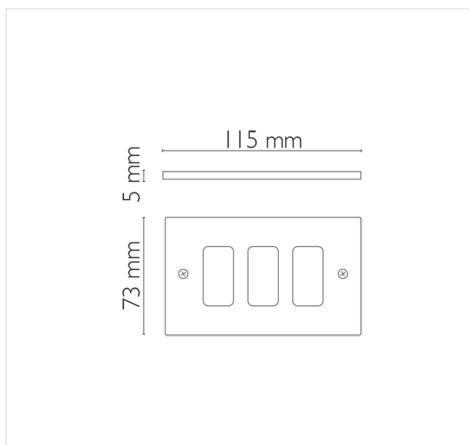

LOGISTICA

EAN Conf.:8028274027198

Pz per Conf.:1

ITF Inner:18028274027195

Pz Inner:10

ITF Master:28028274027192

Pezzi Master:99

Peso Lordo Kg:0.0531

Tipo di Confezione:Busta+Cavaliere/Bag+Headcard

Altezza Inner cm:12

Profondità Inner cm:18

Peso Inner Kg:0.531

Altezza cm:15

Lunghezza cm:13

Profondità cm:1.5



Prodotto Lumi
Certificato IMQ