



**NOVA** line

**NOVA Italia S.p.A.**

Via Vecchia Scorciosa 33-35 - 66022 Fossacesia (Ch)

Tel. 0872 578934 (15 linee r.a.) - Fax 0872 57670

www.novaline.it - info@novaline.it

P.I.: 01956430696 - C.C.I.A.A. CH140833 - Capitale Sociale: € 1.100.000,00 i.v.



RAEE: IT08020000003247



Azienda con sistema

di gestione certificato

ISO 9001: 2015

Certificato N. IT 15/0141

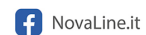

NovaLine.it



novaline.it



novaline.it



# LK2010

PRESA DI CORRENTE 16 A+T, 250V

## INFORMAZIONI

Marca:NOVA LINE

Tipo di Presa:Presca 2 Poli+T 16 A

Colore:Bianco

## CARATTERISTICHE ELETTRICHE

Tensione Nominale:250 V

## LOGISTICA

EAN Conf.:8028274027266

Pz per Conf.:1

ITF Inner:18028274027263

Pz Inner:10

ITF Master:28028274027260

Pezzi Master:99

Peso Lordo Kg:0.0402

Tipo di Confezione:Blister

Altezza Inner cm:12

Profondità Inner cm:18

Peso Inner Kg:0.402

Altezza cm:12.2

Lunghezza cm:7.3

Profondità cm:4.5

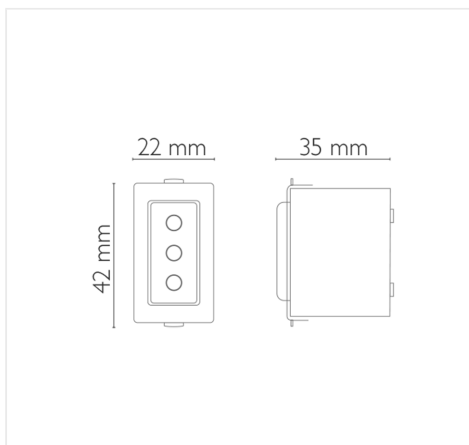

Prodotto Lumi  
Certificato IMQ