



**NOVA** line

**NOVA Italia S.p.A.**

Via Vecchia Scorciosa 33-35 - 66022 Fossacesia (Ch)

Tel. 0872 578934 (15 linee r.a.) - Fax 0872 57670

www.novaline.it - info@novaline.it

P.I.: 01956430696 - C.C.I.A.A. CH140833 - Capitale Sociale: € 1.100.000,00 i.v.



RAEE: IT08020000003247



Azienda con sistema

di gestione certificato

ISO 9001: 2015

Certificato N. IT 15/0141

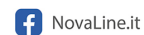

## PB4066X

PANNELLO LED 40 W DIM.595X595 MM, TRI-WHITE  
(4000-5000-6000 K)

### INFORMAZIONI

Marca:NOVA LINE

Materiale:alluminio + polistirene

Altre Caratteristiche:Led Backlit Panel

Colore:Bianco

Tipo di Lampada:Led

Accessori:Kit per montaggio a sospensione

Dimensioni:595x595x25 mm

Uso:Interno

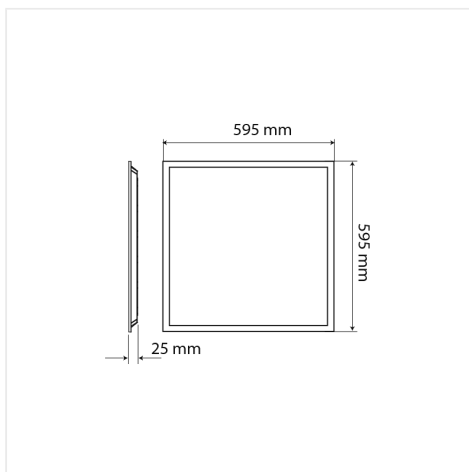

### CARATTERISTICHE ELETTRICHE

Grado di Protezione:IP20

Classe di Isolamento:II

Tensione Nominale:200-240 V

Corrente:156 mA

Fattore di Potenza:>0,9

Potenza:40 W

Temperatura di Funzionamento:-20? / +40?

Frequenza:50/60 Hz



### CARATTERISTICHE ILLUMINOTECNICHE

Lumen (Lm) :3600/3800/3800

Classe Energetica:F

Temperatura di Colore:4000/5000/6000 K

Resa Cromatica:>80

Gradi Diffusione:120°

Numero di Accensioni:12500

Durata in Ore (h):25000

Dimmerabile:No

### LOGISTICA

EAN Conf.:8028274121421

Pz per Conf.:1

ITF Inner:18028274121428

Pz Inner:6

ITF Master:28028274121425

Pezzi Master:999

Tipo di Confezione:Box



**nova**line

**NOVA Italia S.p.A.**

Via Vecchia Scorciosa 33-35 - 66022 Fossacesia (Ch)

Tel. 0872 578934 (15 linee r.a.) - Fax 0872 57670

www.novaline.it - info@novaline.it

P.I.: 01956430696 - C.C.I.A.A. CH140833 - Capitale Sociale: € 1.100.000,00 i.v.



RAEE: IT08020000003247



Azienda con sistema

di gestione certificato

ISO 9001: 2015

Certificato N. IT 15/0141

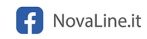

NovaLine.it



novaline.it



novaline.it