



**NOVA** line

**NOVA Italia S.p.A.**

Via Vecchia Scorciosa 33-35 - 66022 Fossacesia (Ch)

Tel. 0872 578934 (15 linee r.a.) - Fax 0872 57670

www.novaline.it - info@novaline.it

P.I.: 01956430696 - C.C.I.A.A. CH140833 - Capitale Sociale: € 1.100.000,00 i.v.



RAEE: IT08020000003247



Azienda con sistema

di gestione certificato

ISO 9001: 2015

Certificato N. IT 15/0141



NovaLine.it



novaline.it



novaline.it

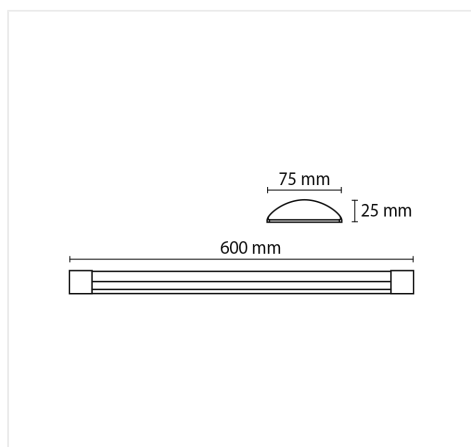

## RBA60X

PLAFONIERA LED LINEARE 18W TRIPLO CCT 60CM, TRI-WHITE 3000K - 4000K - 5700K

### INFORMAZIONI

Marca:NOVA LINE

Materiale:Alluminio e Policarbonato

Altre Caratteristiche:Giuntabile

Tipo di Lampada:Led

Dimensioni:600x75x23 mm

### CARATTERISTICHE ELETTRICHE

Grado di Protezione:IP20

Classe di Isolamento:II

Tensione Nominale:180-265 V

Corrente:129 mA

Fattore di Potenza:>0,5

Potenza:18 W

Frequenza:50/60 Hz

### CARATTERISTICHE ILLUMINOTECNICHE

Lumen (Lm) :2130 - 2330 -2084

Classe Energetica:E

Temperatura di Colore:3000 K - 4000 K - 5700 K

Resa Cromatica:>80

Gradi Diffusione:120°

Numero di Accensioni:12500

Durata in Ore (h):25000

Dimmerabile:NO

Tempo di innesco:istantaneo

### LOGISTICA

EAN Conf.:8028274122619

Pz per Conf.:1

ITF Inner:18028274122616

Pz Inner:20

ITF Master:28028274122613