



NOVA line

NOVA Italia S.p.A.

Via Vecchia Scorciosa 33-35 - 66022 Fossacesia (Ch)

Tel. 0872 578934 (15 linee r.a.) - Fax 0872 57670

www.novaline.it - info@novaline.it

P.I.: 01956430696 - C.C.I.A.A. CH140833 - Capitale Sociale: € 1.100.000,00 i.v.



RAEE: IT08020000003247



Azienda con sistema

di gestione certificato

ISO 9001: 2015

Certificato N. IT 15/0141



NovaLine.it



novaline.it



novaline.it



S01KIT

KIT DI SOSPENSIONE PER PANNELLI LED PER PANNELLI
60X60 E 30X120

INFORMAZIONI

Marca:NOVA LINE

Altre Caratteristiche:4 cavetti in acciaio da 1 mt

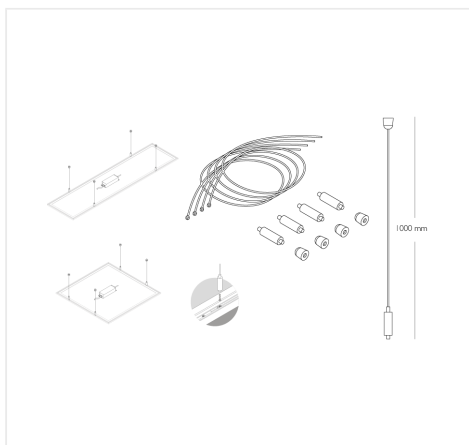

LOGISTICA

EAN Conf.:8028274062175

Pz per Conf.:1

ITF Master:28028274062179

Pezzi Master:99

Peso Lordo Kg:0.102

Altezza cm:14.5

Lunghezza cm:10

Profondità cm:1.5