



novaline

NOVA Italia S.p.A.

Via Vecchia Scorciosa 33-35 - 66022 Fossacesia (Ch)

Tel. 0872 578934 (15 linee r.a.) - Fax 0872 57670

www.novaline.it - info@novaline.it

P.I.: 01956430696 - C.C.I.A.A. CH140833 - Capitale Sociale: € 1.100.000,00 i.v.



RAEE: IT08020000003247



Azienda con sistema

di gestione certificato

ISO 9001: 2015

Certificato N. IT 15/0141



NovaLine.it



novaline.it



novaline.it



TPL150N

PLAFONIERA LED WATERPROOF 60W 150CM, LUCE NATURALE 4000K

INFORMAZIONI

Marca:NOVA LINE

Tipo di Lampada:Led

Dimensioni:1500x65x43 mm

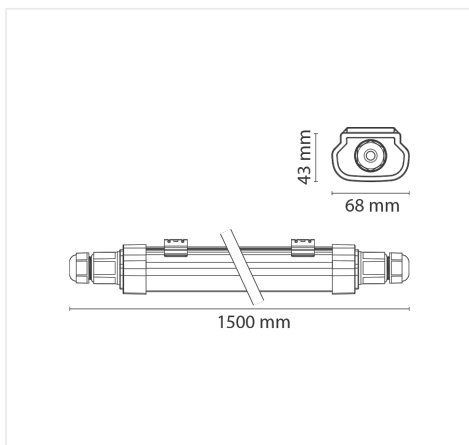

CARATTERISTICHE ELETTRICHE

Grado di Protezione:IP65

Classe di Isolamento:I

Tensione Nominale:220-240 V

Corrente:290 mA

Fattore di Potenza:>0,9

Potenza:60 W

Temperatura di Funzionamento:-20~45°C

Frequenza:50/60 Hz

CARATTERISTICHE ILLUMINOTECNICHE

Lumen (Lm) :6600

Temperatura di Colore:4000 K

Resa Cromatica:>80

Gradi Diffusione:120°

Numero di Accensioni:12500

Durata in Ore (h):25000

Dimmerabile:No

Tempo di innesco:istantaneo



LOGISTICA

EAN Conf.:8028274121575

Pz per Conf.:1

ITF Inner:18028274121572

Pz Inner:20

ITF Master:28028274121579

Pezzi Master:999

Tipo di Confezione:Box